

Sunmodule[®] Protect

SW 250 mono black



Data Sheet



Produced in Germany,
the center for solar technology



www.tuv.com
ID 0000039351

TUV Power controlled:
Lowest measuring tolerance in industry



Above average weather-resistance and
robustness



Sunmodule Protect:
Positive performance tolerance



30 year linear performance warranty and
10 year product warranty



SolarWorld AG relies on Germany as its technology location, thereby ensuring sustainable product quality.

The TUV Rheinland Power controlled inspection mark guarantees that the nominal power indicated for solar modules is inspected at regular intervals and thus ensured. The deviation to TUV is maximum 2 percent.

Innovative glass technologies on front- and backside make extremely weather-resistant and robust solar modules possible. The Sunmodule Protect offers higher mechanical resilience and a longer service life, and still weighs the same as the Sunmodule Plus.

The positive power tolerance guarantees utmost system efficiency. Only modules achieving or exceeding the designated nominal power in performance tests are dispatched. The power tolerance ranges between -0 Wp and +5 Wp.

SolarWorld is setting new standards with the groundbreaking 30-year linear performance guarantee: a maximum degradation of just 0.35% p.a. provides guaranteed module performance of 90% after 21 years, and 86.85% after 30 years.

Sunmodule[®] Protect

SW 250 mono black



PERFORMANCE UNDER STANDARD TEST CONDITIONS (STC)*

		SW 250
Maximum power	P_{max}	250 Wp
Open circuit voltage	U_{oc}	37.8 V
Maximum power point voltage	U_{mpp}	31.1 V
Short circuit current	I_{sc}	8.28 A
Maximum power point current	I_{mpp}	8.05 A

Measuring tolerance (P_{max}) traceable to TUV Rheinland: +/- 2% (TUV Power controlled)

*STC: 1000W/m², 25°C, AM 1.5

PERFORMANCE AT 800 W/m², NOCT, AM 1.5

		SW 250
Maximum power	P_{max}	183.3 Wp
Open circuit voltage	U_{oc}	34.6 V
Maximum power point voltage	U_{mpp}	28.5 V
Short circuit current	I_{sc}	6.63 A
Maximum power point current	I_{mpp}	6.44 A

Minor reduction in efficiency under partial load conditions at 25°C: at 200 W/m², 100% (+/-2%) of the STC efficiency (1000 W/m²) is achieved.

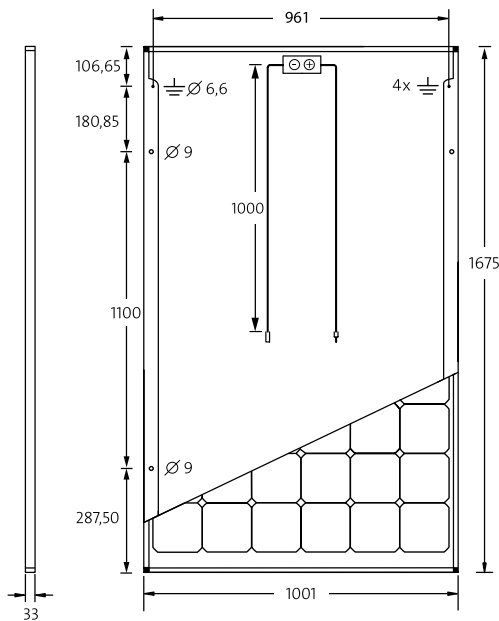

DIMENSIONS

Length	1675 mm
Width	1001 mm
Height	33 mm
Frame	Black anodized aluminum
Weight	21.5 kg

COMPONENT MATERIALS

Cells per module	60
Cell type	Mono crystalline
Cell dimensions	156 mm x 156 mm
Front	tempered glass

THERMAL CHARACTERISTICS

NOCT	48 °C
TC I_{sc}	0.044 %/K
TC U_{oc}	-0.31 %/K
TC P_{mpp}	-0.43 %/K

ADDITIONAL DATA

Power sorting	-0 Wp / +5 Wp
J-Box	IP65
Connector	H4

PARAMETERS FOR OPTIMAL SYSTEM INTEGRATION

Maximum system voltage SC II	1000 V
Maximum reverse current	16 A
Load / dynamic load	5.4 / 2.4 kN/m ²
Number of bypass diodes	3
Operating range	-40 °C to +85 °C

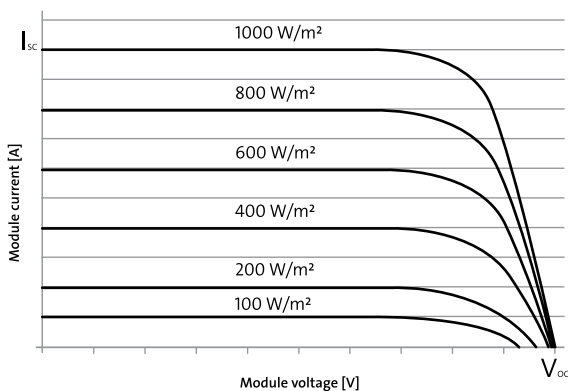

SolarWorld AG reserves the right to make specification changes without notice.
This data sheet complies with the requirements of EN 50380.