

Dimension drawing DV M TT 255 (FM)

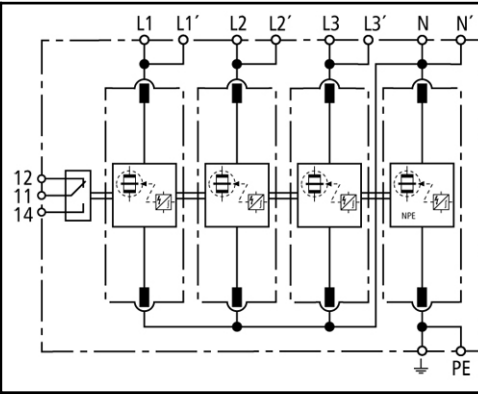

Basic circuit diagram DV M TT 255 FM



DV M TT 255 (FM): Modular combined lightning current and surge arrester for TT and TN-S systems ("3+1" circuit)

- **Prewired combined spark-gap-based lightning current and surge arrester, consisting of a base part and plug-in protection modules**
- **Maximum system availability due to RADAX Flow follow current limitation**
- **No tripping of 20 A gL/gG fuses up to 50 kA<sub>rms</sub> short-circuit currents**
- **Lightning current discharge capacity: 100 kA (10/350 μs)**
- **Allows for protection of terminal equipment**
- **Fault indication by red mark in the inspection window**
- **Easy exchange of protection modules by module locking system with releasing button**
- **Tested for vibration- and shock-proofness acc. to EN 60068-2**

DV M TT 255	
SPD according to EN 61643-11	Type 1
SPD according to IEC 61643-1	Class I
Nominal ac voltage [U <sub>N</sub> ]	230 / 400 V
Max. continuous ac voltage [U <sub>C</sub> ]	255 V
Lightning impulse current (10/350 μs) [L1+L2+L3+N-PE] [I <sub>imp</sub> ]	100 kA
Lightning impulse current (10/350 μs) [L-N] [I <sub>imp</sub> ]	25 kA
Lightning impulse current (10/350 μs) [N-PE] [I <sub>imp</sub> ]	100 kA
Nominal discharge current (8/20 μs) [I <sub>n</sub> ]	25 / 100 kA
Voltage protection level [L-N] [U <sub>p</sub> ]	≤ 1.5 kV
Voltage protection level [N-PE] [U <sub>p</sub> ]	≤ 1.5 kV
Follow current extinguishing capability [L-N] ac [I <sub>ff</sub> ]	50 kA <sub>rms</sub>
Follow current extinguishing capability [N-PE] ac [I <sub>ff</sub> ]	100 A <sub>rms</sub>
Follow current limitation/Selectivity	no tripping of a 20 A gL/gG fuse up to 50 kA <sub>rms</sub> (prosp.)
Response time [t <sub>A</sub> ]	≤ 100 ns
Max. backup fuse (L) up to I <sub>K</sub> = 50 kA <sub>rms</sub>	315 A gL/gG
Max. backup fuse (L) at I <sub>K</sub> > 50 kA <sub>rms</sub>	200 A gL/gG
Max. backup fuse (L-L')	125 A gL/gG
TOV voltage [L-N] [U <sub>T</sub> ]	440 V / 5 sec.
TOV voltage [N-PE] [U <sub>T</sub> ]	1200 V / 200 ms
Operating temperature range (parallel connection) [T <sub>Up</sub> ]	-40°C...+80°C
Operating temperature range (series connection) [T <sub>US</sub> ]	-40°C...+60°C
Operating state/fault indication	green / red
Cross-sectional area (L1, L1', L2, L2', L3, L3', N, N', PE, ±) [min.]	10 mm <sup>2</sup> solid/flexible
Cross-sectional area (L1, L2, L3, N, PE) [max.]	50 mm <sup>2</sup> stranded/35 mm <sup>2</sup> flexible
Cross-sectional area (L1', L2', L3', N', ±) [max.]	35 mm <sup>2</sup> stranded/25 mm <sup>2</sup> flexible
Mounting on	35 mm DIN rail acc. to EN 60715
Enclosure material	red thermoplastic, UL 94 V-0

<b>Degree of protection</b>	IP 20
<b>Dimension</b>	8 mods., DIN 4
<b>Approvals, Certifications</b>	KEMA, VDE
<b>Ordering information</b>	
<b>Type</b>	DV M TT 255
<b>Part No.</b>	<b>951 310</b>
<b>Packing unit</b>	1 pcs.

Change in form and technology, with masses, weights and materials we reserve ourselves in the sense of the progress of the technology. The illustrations are noncommittal.

For more information contact :

SINETECH

Tel : + 27 11 886 7874      Fax : +27 11 787 0178

Email : [sales@sinetech.co.za](mailto:sales@sinetech.co.za)

343 Kent Avenue, Ferndale, Randburg, Johannesburg, South Africa