

TYPICAL HOME BACKUP INSTALLATION DIAGRAM

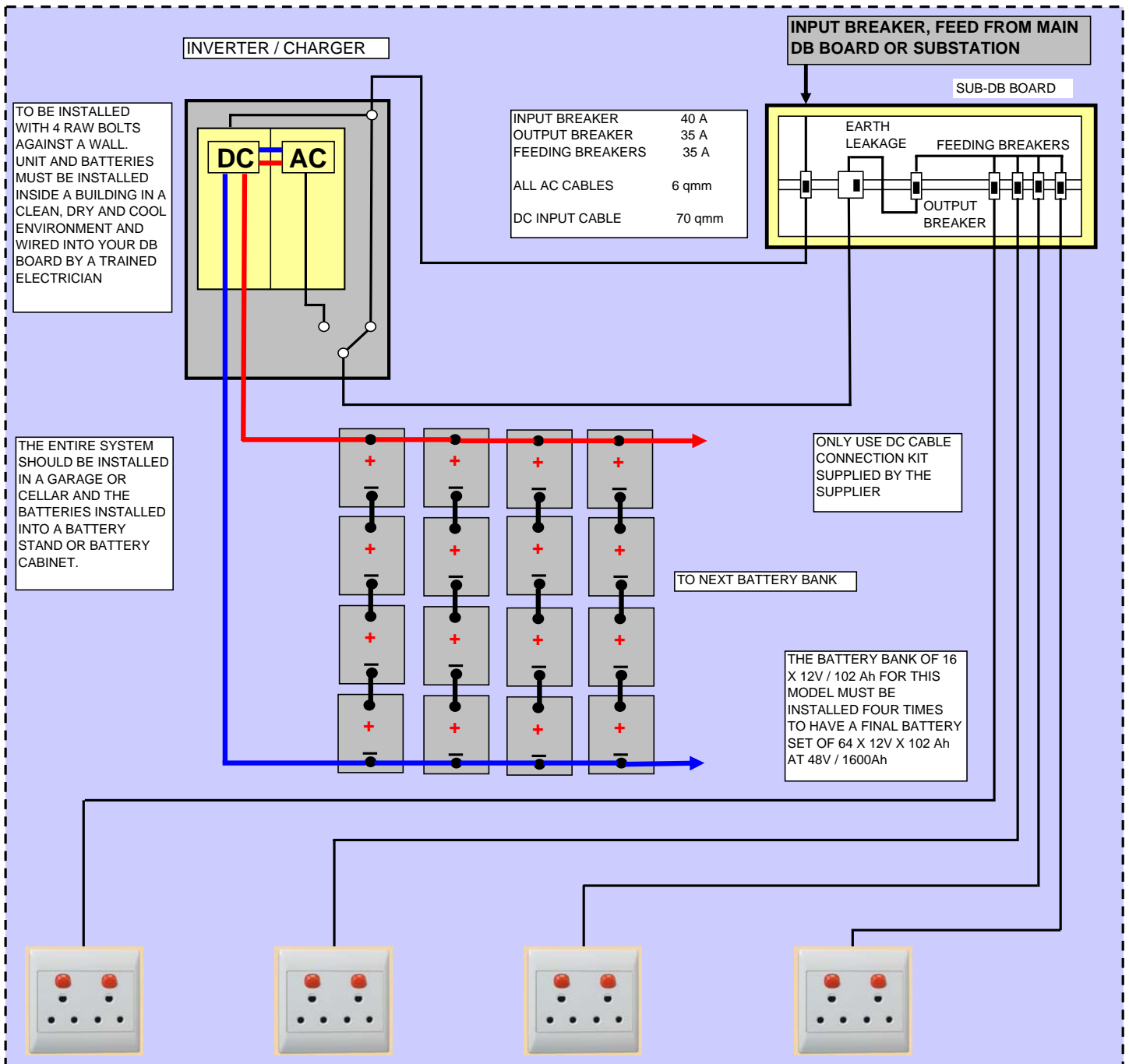

FOR STUDER XPC SERIES MODEL : XPC - 8000 - 48 C

VERSION 01 / 8000 / 48 C / 1600



ATTENTION : Please do not connect underfloor heating, heaters, air conditioners, washing machines, tumble driers, stoves, dishwashers and / or all equipment or appliances which exceed the power output capability of the inverter. If you need to connect any of the above items, please contact our consultants regarding larger inverter systems which are available.